

螺桿尺寸		鋼珠直徑	循環圈數	基本額定負荷(kgf)		螺帽		法蘭					配合	螺絲孔			油孔	剛性	
外徑	導程			(1x10 ⁶ REV.)		Dg6	L	A	T	W	G	H	S	X	Y	Z	Q	kgf / μm	
				Ca(動負荷)	Co(靜負荷)														
14	3	2.000	3	260	460	26	37	46	10	36	-	-	10	4.5	8	4.5	M6x1P	19	
	4	2.381	3	420	805		42	46	10	36	20	40	10	4.5	8	4.5	M6x1P	19	
16	4	2.381	3	435	920	28	42	49	10	39	20	40	10	4.5	8	4.5	M6x1P	21	
	5	3.175	3	765	1240	30	42	49	10	39	20	40	10	4.5	8	4.5	M6x1P	23	
20	5	3.175	3	860	1710	34	47	57	12	45	20	40	12	5.5	9.5	5.5	M6x1P	22	
			4	1100	2280		53											28	
	6	3.969	3	1080	2050	34	53	57	12	45	20	40	12	5.5	9.5	5.5	M6x1P	22	
			4	1380	2730													61	29
25	5	3.175	3	980	2300	40	47	63.5	12	51	22	44	15	5.5	9.5	5.5	M8x1P	26	
			4	1250	3070		53											34	
	6	3.969	3	1275	2740	40	53	63.5	12	51	22	44	15	5.5	9.5	5.5	M8x1P	27	
			4	1630	3650													61	35
10	4.762	3	1620	3205	42	80	69	15	55	26	52	15	6.6	11	6.5	M8x1P	27		
32	5	3.175	3	1095	3060	48	47	73.5	12	60	30	60	15	6.6	11	6.5	M8x1P	32	
			4	1400	4080		53											42	
			6	1980	6120		62											62	
	6	3.969	4	3	1500	3750	48	53	73.5	12	60	30	60	15	6.6	11	6.5	M8x1P	33
				4	1920	5000		61											43
				6	2720	7500		73											64
	8	4.762	4	3	1820	4230	50	68	83	16	66	32	64	15	6.6	11	6.5	M8x1P	33
				4	2330	5640		77											44
10	6.35	4	3	2605	5310	54	80	88	16	70	34	68	15	9	14	8.5	M8x1P	34	
			4	3340	7080		90											45	
40	5	3.175	4	1575	5290	55	56	88.5	16	72	29	58	15	9	14	8.5	M8x1P	50	
			6	2230	7940		65											74	
	6	3.969	4	4	2130	6410	55	65	88.5	16	72	34	68	15	9	14	8.5	M8x1P	52
				6	3020	9620		77											77
	8	4.762	4	4	2720	7620	60	77	93	16	76	36	72	20	9	14	8.5	M8x1P	53
				6	3850	11430		94											79
	10	6.35	4	3	3010	7100	64	83	106	18	84	43	86	20	11	17.5	11	M8x1P	42
				4	3850	9470		93											54
	12	7.144	4	3	4010	9250	70	93	110	18	85	45	90	20	11	17.5	11	M8x1P	44
				4	5130	12330		103											58

■ 之規格有庫存品

FSIC

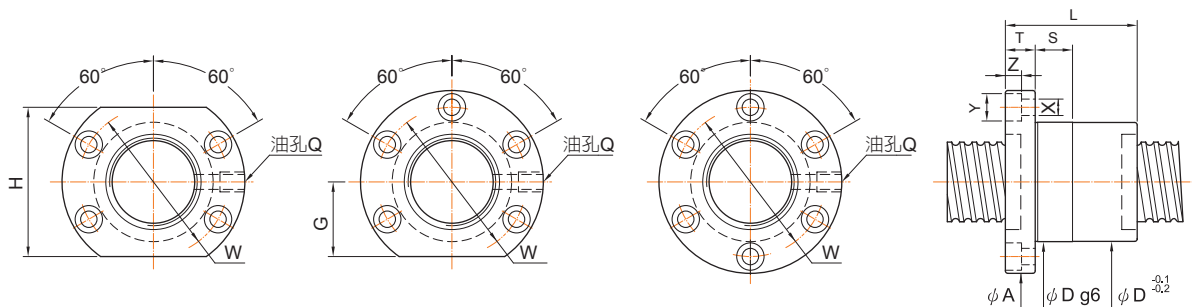

單位:mm

螺桿尺寸		鋼珠直徑	循環圈數	基本額定負荷(kgf)		螺帽		法蘭					配合	螺絲孔			油孔	剛性
外徑	導程			(1x10 ⁶ REV.)		Dg6	L	A	T	W	G	H		S	X	Y		
				Ca(動負荷)	Co(靜負荷)													
50	5	3.175	4	1730	6760	66	55	98	16	82	36	72	20	9	14	8.5	PT1/8"	60
			6	2450	10140		65											89
	6	3.969	4	2380	8250	66	65	98	16	82	36	72	20	9	14	8.5	PT1/8"	62
			6	3370	12380		77											92
	8	4.762	4	3010	9610	70	79	113	18	90	42	84	20	11	17.5	11	PT1/8"	64
			6	4260	14420		96											94
	10	6.35	3	3430	9300	74	83	116	18	94	42	84	20	11	17.5	11	M8x1P	50
4			4390	12400	93		66											
12	7.938	3	4510	11150	75	99	121	22	97	47	94	20	14	20	13	PT1/8"	51	
		4	5770	14870		111											68	
20	7.938	3	4510	11150	75	146	121	28	97	47	94	20	14	20	13	PT1/8"	51	
63	6	3.969	4	2610	10550	80	67	122	18	100	45	90	20	11	17.5	11	PT1/8"	75
			6	3700	15830		80											110
	8	4.762	4	3375	12200	82	80	124	18	102	46	92	20	11	17.5	11	PT1/8"	77
			6	4780	18300		96											114
	10	6.35	4	5020	16450	85	98	132	22	107	48	96	20	14	20	13	PT1/8"	80
			6	7110	24680		118											118
12	7.938	4	6580	19430	90	111	136	22	112	52	104	20	14	20	13	PT1/8"	82	
		6	9320	29150		136											121	
20	9.525	3	8490	23610	95	146	153	28	123	59	118	20	18	26	17.5	PT1/8"	74	
80	10	6.35	4	5510	21200	105	98	151	22	127	57	114	20	14	20	13	PT1/8"	97
			6	7810	31800		118											143
	12	7.938	4	7500	25700	110	111	156	22	132	59	118	20	14	20	13	PT1/8"	100
			6	10620	38550		136											147
20	9.525	3	9770	31700	115	146	173	28	143	66	132	20	18	26	17.5	PT1/8"	86	
		4	12510	42270		168											113	

■ 之規格有庫存品